

T. J. SLOAN.  
Making Screws.

No. 9,688.

Patented April 26, 1853.

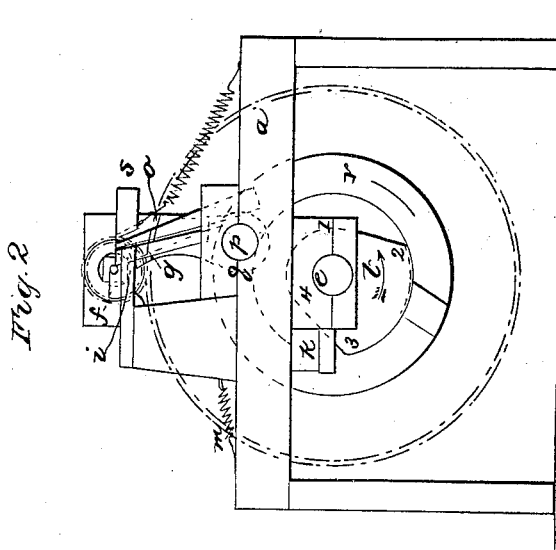

*Fig. 3.*

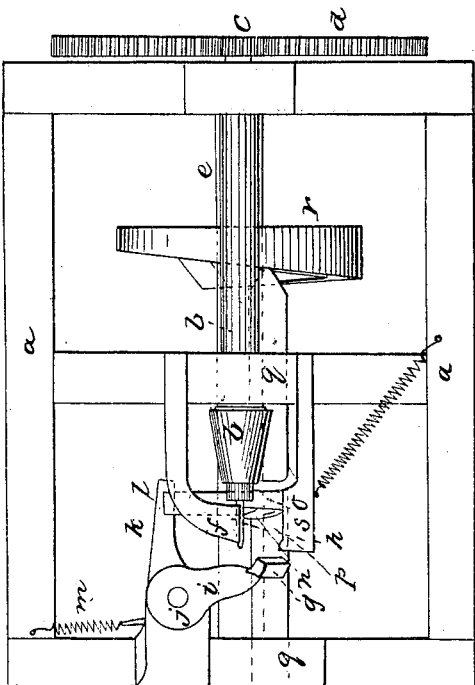

*Fig. 1*

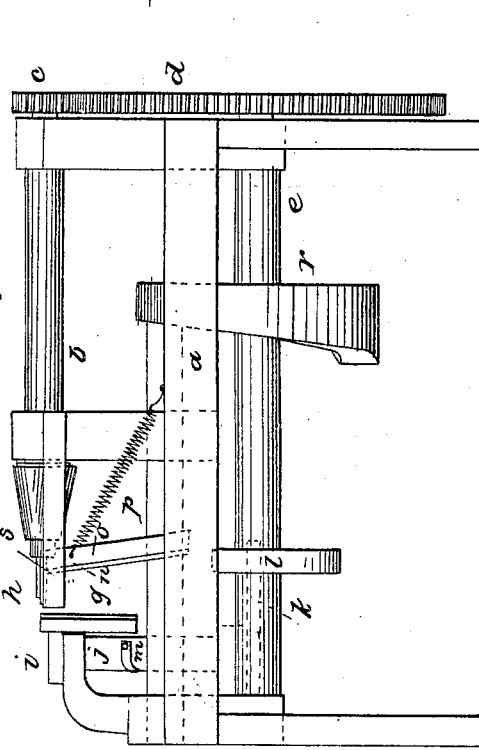

# UNITED STATES PATENT OFFICE.

THOMAS J. SLOAN, OF NEW YORK, N. Y.

## MACHINE FOR POINTING AND THREADING SCREW-BLANKS.

Specification forming part of Letters Patent No. 9,688, dated April 26, 1853.

*To all whom it may concern:*

Be it known that I, THOMAS J. SLOAN, of the city, county, and State of New York, have invented a certain new and useful Machine for Pointing and Threading Wood-Screws, and I do hereby declare that the following is a full, clear, and exact description thereof, reference being had to the accompanying drawings, making part of this specification, in which—

Figure 1 is a side elevation; Fig. 2, an end elevation; and Fig. 3, a plan.

The same letters indicate like parts in all the figures.

My invention relates to the method of pointing screw-blanks and cutting the threads thereon.

My invention consists in combining, in an organized machine, a cutter and its appendages for forming the point in screw-blanks with the chaser or cutter which cuts the thread over the shank and pointed part thereof down to the point.

In the accompanying drawings, *a* represents the frame of the machine, and *b* a mandrel, which is to be constructed in any appropriate and well-known manner, and provided with the usual appendages for gripping and rotating the blank and receiving motion by a pinion *c* from a cog-wheel *d* on the cam-shaft *e*. The whole is to be driven in any appropriate manner. After a blank has been inserted it is to be supported in the usual manner at the back by a rest *f*, which is to be operated in any well-known or appropriate manner.

There is a cutter *g* of the proper form to make the point on the blank *h*. This cutter is secured to a horizontal tool-post *i* on the upper end of a rock-shaft *j*, hung in proper bearings, and at the lower end this rock-shaft is provided with an arm *k*, which is made to bear against the periphery of a cam *l* on the cam-shaft *e* by a spring *m*. The cam *l* from the point 1 to 2 in the direction the reverse of the arrow runs out from the axis for the purpose of carrying the cutter up to the blank. From 2 to 3 it very gradually and slowly recedes from the axis to force the cutter against the blank to form the point, and then from 3 to 4 it runs in toward the axis to per-

mit the spring *m* to draw back the cutter after the point has been formed.

The cutter or chaser *n* is attached in the usual manner to the tool-post *o* on a rock-shaft *p*, which slides longitudinally in its bearings *q*. The chasing motion is communicated to the rock-shaft by the cam *r* on the cam-shaft *e*, as is well known to persons acquainted with machinery for threading wood-screws.

The motion of the chaser toward and from the axis of the screw-blank during the threading motions is given by the mold *s*, which is to be operated in manner well known to persons acquainted with machinery for threading screws.

As the mode of operating the mandrel, the rest, and the chaser makes no part of my present invention, and these may be constructed and operated in any efficient manner, it is not deemed necessary to describe and represent them in details. The chaser can begin the chasing operation while the cutter is shaping the point, provided the latter be withdrawn in time to permit the chaser to form the thread on the point.

I wish it to be understood that I do not limit myself to the precise manner of mounting and giving the required motions to the cutter for forming the point on the blank or the chaser for forming the thread on the shank and point, as these may be varied by the substitution of mechanical equivalents.

I am aware that Letters Patent were granted to L. D. Walter and Jacob Walter on the 7th of February, 1842, for an instrument or tool to be applied to a mandrel or lathe for the making of screw-bolts in which there is a cutter for cutting or reducing the diameter of the rod to form the shank and leave the head, and then to cut off the bolt from the rod, leaving a conical point, and having this combined with dies for forming a thread on the shank; but such instrument is not applicable to nor could it be employed in the manufacture of wood-screws from wire with the head "swaged up," as it is termed, nor is the said instrument adapted to the forming of a complete thread on the conical point, and therefore I do not wish to be understood as making claim, broadly, to the combination of a

cutter for pointing with the dies for forming the thread on the cylindrical part of the shank; but

What I do claim as my invention is—

Combining, in an organized machine, a cutter and its appendages, operated substantially as specified, for forming the point on screw-blanks, as specified, with the chaser or

cutter which cuts the thread over the shank and pointed part thereof down to the point, substantially as specified.

THOS. J. SLOAN.

Witnesses:

WM. H. BISHOP,

CHARLES N. BAMBURGH.