

S. Beers,

Turning Irregular Forms.

N^o 7,806.

Patented Dec. 3, 1850.

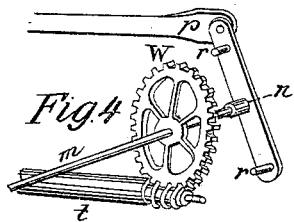
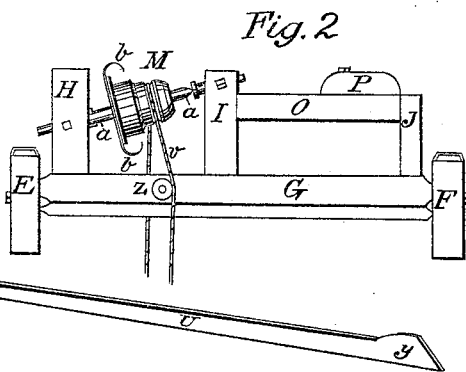
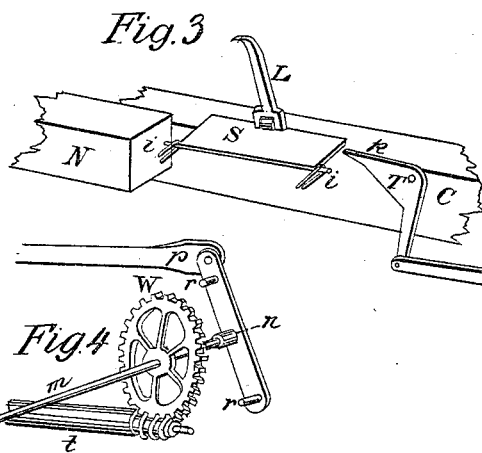
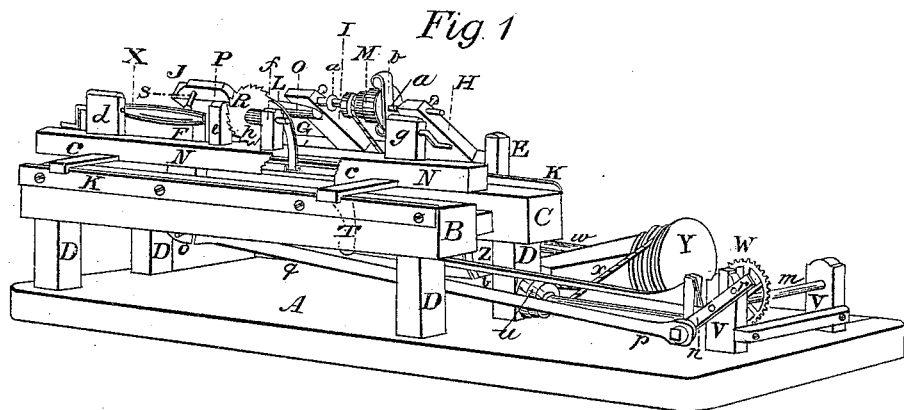

UNITED STATES PATENT OFFICE.

SMITH BEERS, OF NAUGATUCK, CONNECTICUT.

MACHINE FOR TURNING IRREGULAR FORMS.

Specification of Letters Patent No. 7,806, dated December 3, 1850.

To all whom it may concern:

Be it known that I, SMITH BEERS, of Naugatuck, in the county of New Haven, and State of Connecticut, have invented a
5 new and useful Machine for Cutting and Shaping Spokes of Carriage-Wheels and other Similar Work; and I do hereby declare that the following is a full and exact description of the construction and operation
10 of the same, reference being had to the annexed drawings, making part of this specification, of which—

Figure 1 is a perspective view. Fig. 2 is a section representing the rear side of the cutter frame and inclined mandril, and
15 Fig. 3 is a section representing the connection of a part of the machinery by which the position of the rough material is changed, Fig. 4 is a section showing the screw wheel and crank.
20

The general principles of this machine are similar to those of a machine invented in 1818 and known as the Waterbury last making machine but very differently arranged.
25

Upon a platform A is constructed a strong frame consisting of two horizontal beams B and C supported by four posts D D D. To the rear side of the rear beam
30 C is attached two hanger arms H I and a gage arm J the two first support the bearings of a mandrel *a a* on which is mounted a cutter pulley M with a pair of bent cutters *b b* as fully shown in Fig. 2.

35 The cutter mandrel is mounted in an oblique position for the advantage of cutting more freely.

The arms I and J are connected by a horizontal bar O to which is attached a
40 gage block P.

To the outside of each beam is attached a plate of iron K which extends a little above the top of the beam; and these plates serve as ways to a sliding carriage consisting of two horizontal sliding bars *c c* and a carriage beam N mounted centrally thereon
45 (in the drawings a part of this beam is removed to show the pushing pall L in the rear) upon the carriage beam are four puppet heads *d e f g*.
50

The puppets *d* and *g* are furnished with center screws like those of a lathe; and the puppets *e* and *f* support a ratchet mandrel *h* which has a swallow tail at each end, and
55 on its center is mounted a ratchet R.

A lifting plate S is connected to the rear of the carriage beam by hinge joints *i i* Fig. 3; and to the rear of this plate is connected by another hinge joint, a pushing pall L the point of which takes to the
60 ratchet R.

A knee lever T represented by dotted lines is connected by a fulcrum pivot *j* to the front of the beam G in such a manner that the horizontal leg *k* Fig. 3 of the lever
65 stands under the lifting plate while the other descends and is connected to the left end of a horizontal sliding rod U supported and guided by a small post *i* (the lifting plate *s* should be made longer than the longest spoke or other article intended to be wrought so that the vibratory motion will not carry it off the knee lever).
70

On the right of the platform are two bearing posts V V which support a horizontal shaft *m* on which is mounted a screw wheel W as shown in Fig. 4 and to the front end of which is attached a crank *n*. This crank is connected to a horizontal shackle bar *p q*, the left end of which is connected
80 to the carriage beam or to a hanger *o* which projects downward from the carriage beam; thus the crank vibrates the carriage; and on the rear side of the crank are two pins *r r* Fig. 4 which alternately impinge upon
85 the beveled end *y* of the sliding rod U forcing it to the left, by which movement the lifting plate and pushing pall are elevated by the knee lever T and the ratchet and mandril are thereby moved to a different
90 position.

The space between the puppets *d* and *e* Fig. 1 is occupied by a properly formed wheel spoke X or other article which is to be imitated in shape and upon this rests the gage pin *s* Fig. 1 which projects from the gage block P. The space between the puppets *f* and *g* is occupied occasionally by a stick of timber which is to be cut
100 nearly to the shape of the pattern X; both the pattern and the rough timber are supported by and between their respective screw-centers and swallow-tails or turning points, neither the ratchet, mandrel, pattern nor timber revolves during each longitudinal vibration of the carriage; but the elevation of the cutter-mandril is regulated by the shape of the pattern on which the gage pin rests or slides. The screw wheel W Fig. 4 is put in motion by a screw shaft *t*
110

on the left end of which is a pulley *u* which
is connected by a cross band *x* to a band
wheel *Y* mounted on a rear driving shaft
w. Another band wheel *z* is mounted on
5 the rear shaft and communicates motion by
another band *v* to the cutter pulley *M* the
band being guided thereto by the guide
pulley *z* Fig. 2. The motion is communi-
cated to the driving shaft by means of a
10 crank, drum, gear wheel or otherwise.

I do not claim the use of a pattern to
govern the action of the cutters; nor do I

claim the revolving cutters; nor the longi-
tudinal vibration of the machine. But

What I do claim as original and desire 15
to secure by Letters Patent is—

The mode herein described of changing
the position of the ratchet *R* by means of
the arrangement of the sliding rod knee
lever lifting plate and pall.

SMITH BEERS.

Witnesses:

RALPH SMITH,
DICKERMON COOK.