

(No Model.)

J. FLATHER.
FEED MECHANISM FOR LATHES.

No. 317,449.

Patented May 5, 1885.

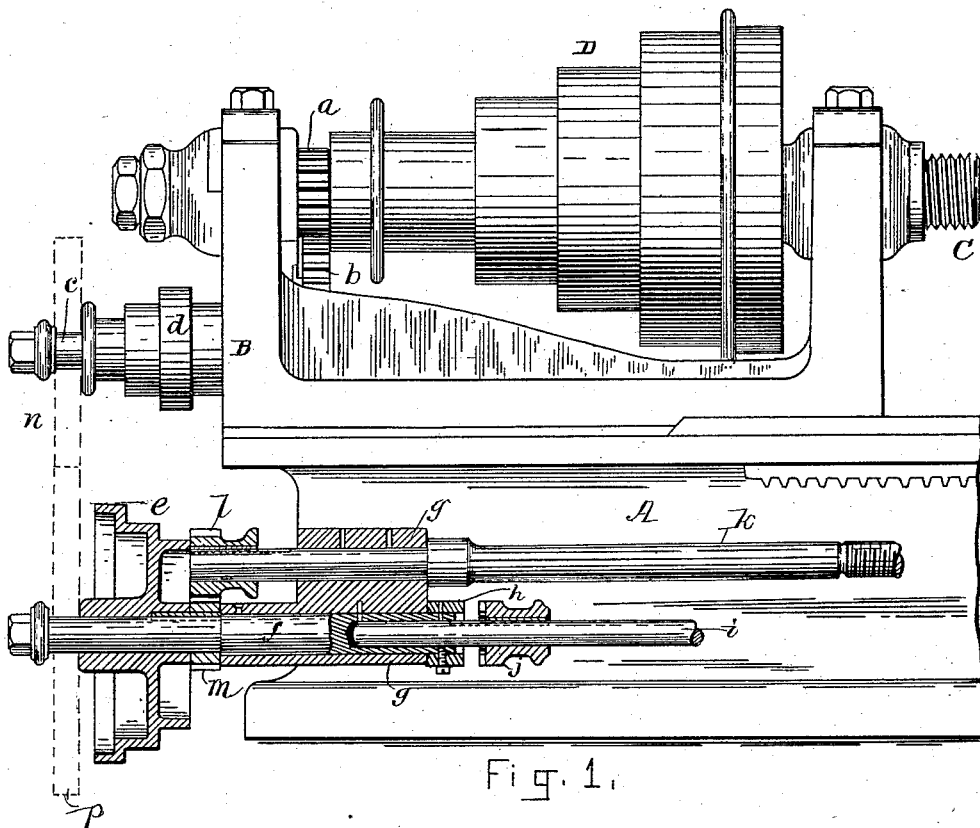

Fig. 1.



Fig. 2.

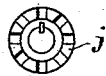

Fig. 3.

WITNESSES:
Chas. S. Gooding
Eugene Humphrey

INVENTOR:
Joseph Flather
per Porter & Hutchinson
Atty

UNITED STATES PATENT OFFICE.

JOSEPH FLATHER, OF NASHUA, NEW HAMPSHIRE.

FEED MECHANISM FOR LATHES.

SPECIFICATION forming part of Letters Patent No. 317,449, dated May 5, 1885.

Application filed February 16, 1885. (No model.)

To all whom it may concern:

Be it known that I, JOSEPH FLATHER, of Nashua, in the county of Hillsborough and State of New Hampshire, have invented a
5 new and useful Improvement in Feed Mechanism for Engine-Lathes, which will, in connection with the accompanying drawings, be hereinafter fully described, and specifically defined in the appended claims.

10 This invention has for its object an improvement in the feed mechanism of engine-lathes, by which the cutting-tool is moved relatively to the article on which it is acting, either when
15 turning the surface thereof or when cutting a screw-thread thereon, and it will, in connection with the accompanying drawings, be hereinafter fully described and distinctly claimed.

In said drawings, Figure 1 is a side elevation showing a portion of a lathe-bed, the
20 head-stock thereon mounted, and the left-hand portion of the feed-rod, the screw-cutting feed-rod, and the devices by which they are actuated. Figs. 2 and 3 are end views of the parts
25 of the clutch by which the two parts of the feed-rod are coupled together.

In said views, A represents the left-hand portion of a lathe-bed. B is the head-stock mounted thereon. C is the arbor, and D the cone-pulley on the arbor. A gear, *a*, mounted
30 on the arbor and meshing into gear *b*, serves in the usual manner to rotate stud *c*, on which is mounted the small cone-pulley *d*, all said parts being old, common, and well known, and susceptible of the various well-known changes
35 and modifications. The usual cone-pulley *e*, to be actuated by a belt from cone-pulley *d*, is mounted on section *f* of the rod known as the "feed-rod"—that is, the rod through which
40 the cutting-tool is moved parallel to the bed when finishing the surface of any piece being revolved in the lathe. Said section *f* of the feed-rod is journaled in bearing *g*, which may be either formed upon or secured to bed A,
45 and said section is secured from lineal displacement by gear *m* and pulley *e*, secured upon it on one side of bearing *g*, and clutch *h*, secured upon it on the other side. A longer section, *i*, of the feed-rod is telescopically
50 arranged to revolve freely in section *f*, and may at will be interlocked therewith by means of its toothed collar *j*, which is splined on said

section *i* to insure coincident rotation, and which slides freely to be interlocked with clutch-collar *h* on section *f*, and when so interlocked both sections of the rod revolve
55 together. Said section *i* extends to and is combined with the feed devices arranged in the apron or curtain that depends from the carriage or slide on which the cutting-tool is mounted in the tool-post. The screw-cutting
60 feed-rod *k* is also journaled in bearing *g*, and carries a pinion, *l*, interlocked therewith by a spline, but having free lineal adjustment thereon.

When finishing the cylindrical surface of
65 any article, pinion *l* is disconnected from pinion *m* by sliding it upon rod *k* against bearing *g*, thereby leaving rod *k* idle, and clutch-collar *j* is interlocked with collar *h*, thereby interlocking sections *f i* of the feed-rod; but
70 when cutting screw-threads upon any article mounted in the lathe clutch-collars *h j* are disconnected and pinions *l m* are enmeshed, as shown, when section *i* will remain idle, while
75 rod *k* will be driven through section *f* and its pinion *m*.

When actuating rod *k* through section *f* for screw-cutting, as stated, said section will of course be driven through gears shown by dotted lines at *n p*, respectively mounted on
80 section *f* and stud *c*; but when rod *k* is idle and the feed-rod *i* is operative it will usually be driven by the belt on cones *d e*; but if a feed coarser or finer than can thereby be obtained
85 is required, the same may be effected by selecting properly-differentiated gears and mounting the same on *f* and *e*, and thereby driving rod *i*, the cross-feed being also driven
90 by either of these methods, as may be preferred, or as the coarseness of the cut may render necessary.

I claim as my invention—

1. The combination of the divided feed rod *f i* with means to interlock or liberate the
65 same, and the screw-cutting feed-rod *k*, with gears adapted to be enmeshed and separated, and to impart the rotation of section *f* to said rod *k*, substantially as specified.

2. The combination of divided feed rod *f i*, clutch-collars *h j*, respectively mounted
100 thereon and adapted to be interlocked or separated, screw-cutting feed-rod *k*, and gears *l*

m, respectively mounted thereon and adapted to be enmeshed or disconnected, substantially as specified.

5 3. The divided feed-rod formed with section *i*, telescoped or inserted in a longitudinal cavity in section *f*, said sections being respectively provided with clutch devices adapted to interlock the same and secure their coincident rotation, substantially as specified.

10 4. The combination of a feed-rod formed in two sections with devices to interlock or separate the same, and a screw-cutting feed-rod with gears arranged thereon and upon the constantly-operative section of said divided
15 feed-rod, and arranged to be enmeshed or separated at will, substantially as specified.

20 5. The combination of a feed-rod constructed and arranged to be driven at will, either by a belt or by gears, and a screw-cutting feed-rod, combined and arranged to be

actuated by said feed-rod, substantially as specified.

6. The combination, with the two feed-rods, of gears respectively mounted thereon and arranged to be enmeshed or disconnected, 25 whereby one rod may at will be driven by the other or disconnected and remain idle while the other is operative, substantially as specified.

7. The combination of the two feed-rods 30 with means whereby one may at will be driven through or by the other, the rod thus driving the other being formed in two sections or lengths and provided with coupling devices, whereby its sections may at will be secured 35 together or disconnected, substantially as specified.

Witnesses: JOSEPH FLATNER.

G. W. DAVIS,

A. MCKEAN.