

(No Model.)

D. E. & L. E. WHITON.

LATHE CHUCK.

No. 294,296.

Patented Feb. 26, 1884.

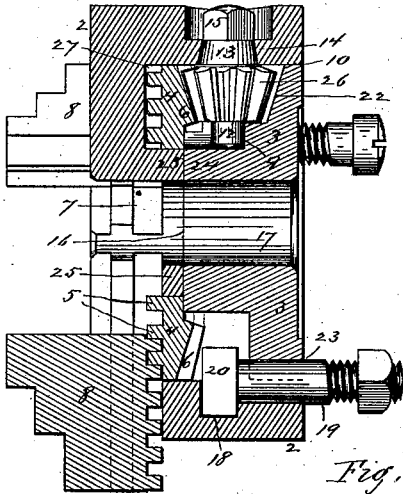

Fig. III

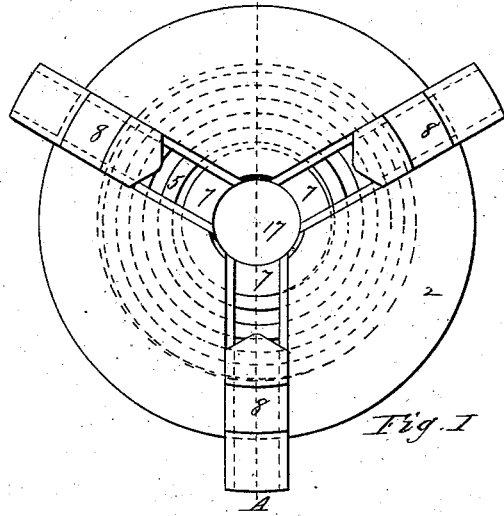

Fig. I

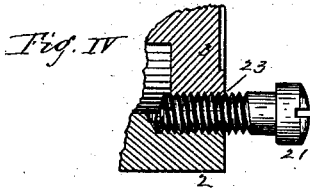

Fig. IV

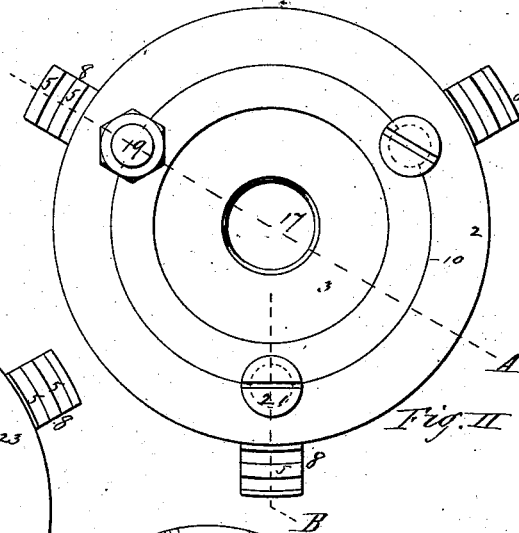

Fig. II

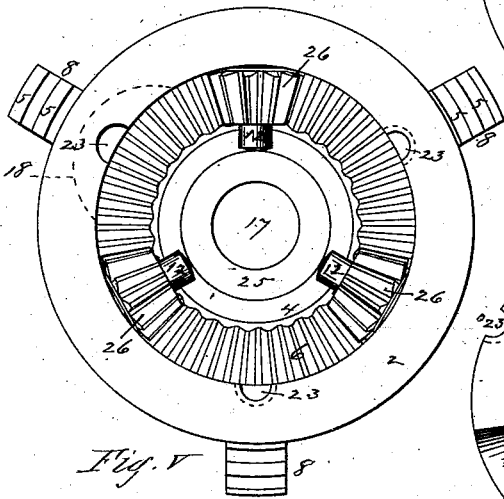

Fig. V

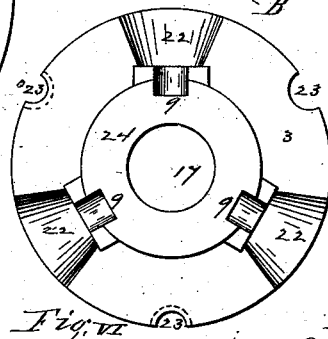

Fig. VI

Witnesses.
Chas. H. Wood
C. E. Boston.

Inventors.
David E. Whiton.
Lucius C. Whiton.
By T. Alister,
their atty.

UNITED STATES PATENT OFFICE.

DAVID E. WHITON AND LUCIUS E. WHITON, OF WEST STAFFORD, CONN.

LATHE-CHUCK.

SPECIFICATION forming part of Letters Patent No. 294,296, dated February 26, 1884.

Application filed May 9, 1883. (No model.)

To all whom it may concern:

Be it known that we, DAVID E. WHITON and LUCIUS E. WHITON, both of West Stafford, in the county of Tolland and State of Connecticut, have invented a new and useful Improvement in Lathe-Chucks, of which the following is a specification and description.

Our invention relates to that class of lathe-chucks whose jaws are moved radially in guide ways or slots made in the front face of the shell or case by a rotary disk operated by pinions within the shell, and provided with a convolute or scroll thread made on its outer face, which engages in the teeth made on the back side of each jaw.

The object of our invention is to secure the greatest strength, durability, and accuracy in and to completely inclose all the actuating parts, to give easy access to the same when desired, and to provide means to secure the back plate to the shell at the same time the chuck is secured to the chuck-plate. We accomplish this by the mechanism substantially as hereinafter described, and illustrated in the accompanying drawings, in which—

Figure I is a front view of a chuck made according to our invention, showing the jaws, the guideways in which they are moved, and the scroll which actuates them. Fig. II is a rear view of the same, showing the back plate secured in place in the shell by the bolts or screws. Fig. III is a longitudinal section of the chuck at line A. Fig. IV is a section of a portion of the chuck at line B, showing the method of securing the back plate to the shell. Fig. V is a view of the inside of the chuck with the back plate removed, and showing the operating-pinions and the toothed scroll-disk; and Fig. VI is a view of the inside face of the back plate, showing the bearings for the inner journals of the pinions.

In the drawings, 2 represents the shell or case of the chuck, which is open at its rear end, with a back plate, 3, snugly fitted in the open end, and secured therein by screws or bolts fitted into holes 23, one half of each said hole being made in the edge of the back plate, and the other half being made in the inner edge of the open end of the shell. Radial guideways 7 are made in the front face of the

shell 2, which guideways extend entirely through the shell and into the annular recess 27, made in the inside of the shell, to receive the disk 4, on whose outer face is made a convolute or scroll thread, 5, which engages with the teeth made on the back side of the jaws 8, as shown clearly in Fig. III. This disk fits well the recess 27, but so as to revolve freely therein, and its inner face is provided with beveled teeth 6, extending all around, as shown clearly in Fig. V.

The operating-pinions 26, of which there may be three, have their teeth beveled to fit the beveled teeth of the disk 4, and the outer journal, 13, of each pinion is of the same taper as that of its beveled teeth 26, but in the opposite direction, and has a bearing in a tapered hole, 14, made through the shell 2, the outer end of the journal 13 being smallest in diameter, and of prismatic form, to receive an operating-key; and the inner journal, 12, has a bearing in a recess, 9, made in the back plate, 3. By making the bearings or holes for the pinions of a tapered form and in the shell itself and the journals of the pinions of corresponding tapered form, we are enabled to insert the pinions into place from the inside, with a very small joint exposed on the outside of the shell; and the beveled teeth of the pinions, when in place, engage with the beveled teeth of the disk their entire depth, which could not be the case without this feature of tapered journals and journal-bearings for the pinions. An annular projection or boss, 24, is made on the inner side of the back plate, 3, which, when said plate is inserted in place, impinges against the inner face of an annular flange, 25, extending around the inside of the disk and around the outside of the central hole, 17, which is made entirely through the chuck at its axis; and when the back plate, 3, is placed in position it is secured by fastening screws or bolts, as hereinbefore mentioned. When the back plate is removed from its place, by removing the bolts or screws 21, the pinions 26 may be removed from or inserted into place from the inside of the shell. As the taper of the outer journal, 13, of each pinion in its bearing 14 is the same with reference to its axis as the incline or bevel of its teeth and

of the teeth on the disk, although in an opposite direction, this feature permits the pinions to be easily inserted in place and removed therefrom for any purpose. Inasmuch as the thrust of each pinion in its bearing, when in operation, is outward, or toward the side opposite the disk 4, a cavity or bearing, 9, is made in the back plate, 3, to give support to the inner journal, 12, of each pinion, said plate also being recessed at 22, if necessary, to make room for the teeth of the pinion.

The outer rim of the back plate, where it fits into the shell, is shown at 10, and is secured to the shell by inserting the bolts or screws 21 through the plate. For the smaller sizes we prefer to thread the holes 23 and insert screws through the plate and turn them into the threaded holes; but for the larger sizes we prefer to mill out a curved cavity, 18, (shown in Fig. III and also in dotted lines in Fig. V;) and instead of threading the holes 23 at the joint between the back plate and the shell, we leave the holes smooth and place a bolt, with its outer end threaded, upon which to turn a nut. When the bolt is in place, its head on one side impinges against the inner wall of this cavity, and the bolt is thus held firmly by its position in the hole; and when the nut is turned up to its bearing against the plate, in securing the latter in place on the rear end of the chuck, the bolt cannot turn.

It is evident that by making the shell solid or in one piece at the bearings of the pinions we produce a much stronger chuck, and the bearings of the pinions are much more accurate and durable, and at the same time lessen the expense of manufacture; and when constructed as above described the liability of the parts getting out of order or disarranged is reduced in a great degree.

Having thus described our invention, what we claim as new is—

1. In a geared scroll-chuck, the shell or case 2, provided with tapered holes for pinion-bearings, in combination with a series of pinions, each having a tapered journal to revolve in one of said tapered holes in the shell, and a back plate fitted to the open rear end of said shell, substantially as described.

2. In a geared scroll-chuck, the shell or case 2, having its rear end open, in combination with a back plate fitted into said open end, and holes made partly in said plate and partly in said shell at the joint, and screw-bolts adapted to extend through the chuck-plate of a lathe and fitted into said holes, whereby said back plate is secured in place and the chuck secured to the chuck-plate of the lathe by the same set of screw-bolts, substantially as described.

3. In a geared scroll-chuck, the shell or case 2, provided with tapered holes for pinion-bearings, in combination with a back plate fitted and secured in the open end of said shell, a series of pinions, each having its outer journal tapered and adapted to revolve in one of the tapered holes in said shell, and its inner journal supported in a bearing in said back plate, the toothed scroll-disk, the jaws adapted to move in the radial guideways, and the screw-bolts fitted to the holes at the joint in the back plate and the shell or case, and adapted to extend through the chuck-plate of a lathe, substantially as described.

DAVID E. WHITON.
LUCIUS E. WHITON.

Witnesses:

T. A. CURTIS,
CHAS. H. WOOD.